



OMEGA

740/750
745/755
harness manufacturing



komax

OMEGA

740/750
745/755

The Omega 740/750 makes it possible to produce wire harnesses of varying degrees of complexity and for terminal housings to be loaded on one side or both sides. Five (Omega 740) or eight (Omega 750) modules can be selected, as required. The Omega 740/750 is the economical answer to ongoing miniaturization and increasingly smaller batches. These machines make it possible to manufacture a range of different wire harnesses and reduce production time significantly.

The Omega 745/755 application machine is essentially identical in construction to the Omega 740/750. However, the pallet system is replaced by a fully automatic conveyor system. The application is an automated solution developed specifically for the customer for the feeding and further processing of housings and depositing of the wire harnesses. Additional follow-on processes can also be incorporated. Read more about the application machine on the following pages.

High efficiency – less storage requirement

- Shortest lead times – significantly reduced production time
- Minimized stock level of semi-finished products
- Optimized production process

High-quality wire harnesses thanks to automated processes

- Continuous quality, independent of the operator
- Reliable loading of miniaturized components
- Monitoring of the insertion process using force sensors
- Optional ACD incision monitoring

High flexibility

- Single-sided or double-sided loading with terminals of varying levels of complexity
- Omega 740/750: standard machine with loading on pallet carousel, quick and individual changeover
- Omega 745/755: individually constructed loading solution for special requirements

▶ The optical terminal measurement system enables the insertion of a wide range of terminals.

QUANTUM LEAP IN FULLY AUTOMATIC WIRE HARNESS PRODUCTION

Guaranteed quality of the end products

The quality of the end product is continually guaranteed, independent of the machine operator. A high-precision force sensor monitors the entire insertion process and correct latching of the terminal parts in the housing. The individual default values are synchronized. As a result, the insertion of small components, which can hardly be inserted by hand, is carried out in an absolutely reliable manner – supported by a precise and fast spindle drive. With direct production of wire harnesses and by removing interim storage, the danger of terminals being damaged through the storage process or from mistakes and incorrect loading is also eliminated. The optional ACD incision monitoring reduces operator influence and ensures quality monitoring even for the smallest wire diameters. The ACD detects the slightest contact between the blades and conductor strands during stripping.

Continuous data flow and traceability

Production data can be sent directly to the machine via a network. The quality data from the production process is saved for each wire harness and traceability is guaranteed at all times.

Comprehensive advice for functional implementation

Komax brings the corresponding expert knowledge for the automation of wire harness production with the Omega. Specialists evaluate the design of the wire harnesses and components with regard to automated processing. They present design proposals and assist companies in the optimal integration into their production process.



01

Wide variety with up to 36 wire types

The different wire types for versatile wire harness production are available on the Omega machines without the need for changeovers. The automatic wire changer provides up to 36 different wires from the entire cross-section range. This enables the range of wires required in the construction of control cabinets, for example, to be covered perfectly.

High-resolution labeling in black or color

Two automated inkjet printers mark the wires in black and one additional color within the same sequence. After that, the wires are picked up by a shuttle system and guided in loops to the processing machines.

01
The wire changer holds up to 36 different wires from the entire cross-section range ready for processing.

02
The automatic marking system with two different inkjets provides optimal labeling of the wires.

ACD incision monitoring

The ACD detects the slightest contact between the blades and conductor strands during stripping. It is based on a capacitive measuring principle, is integrated in the blade holder and can be operated using any standard stripping blade. The sensitivity of the monitoring can be configured using setting parameters. Defective wire ends are detected automatically and rejected.

Untwisting of the wires

Unwound wires are always twisted. A special untwisting module removes this twist. The wires are then 100% straight, which is crucial for the subsequent fully automatic insertion.

03
Three pairs of blades with optional incision monitoring (ACD) cover the entire cross-section range of 0.13 to 2.5 mm² (AWG 26 – 14)

04
Untwisting modules neutralize twisted wires.

03

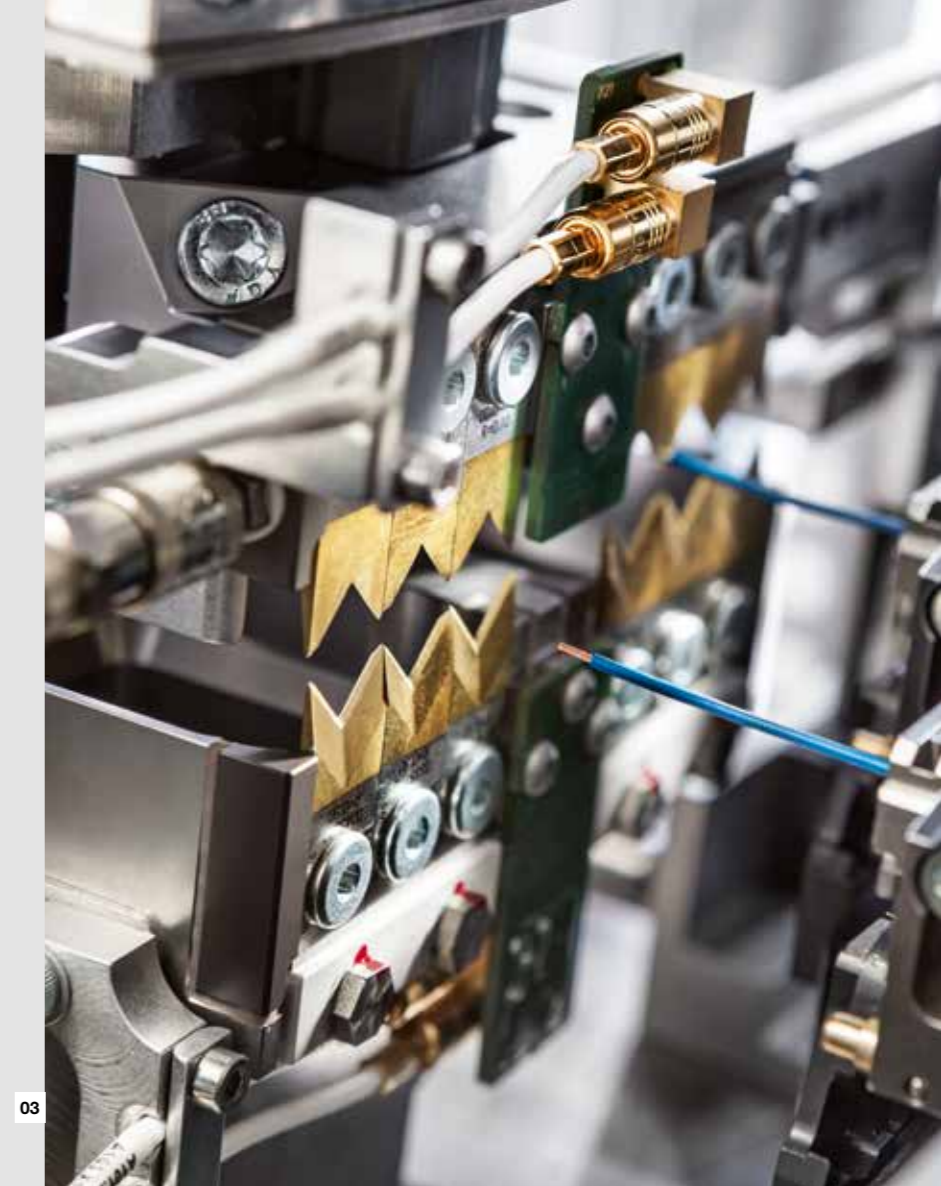

04



02



Shorter lead times – less storage requirement – optimized process

Decisive savings in time and logistics and a corresponding growth in productivity can be achieved thanks to the absence of manual steps, interim storage and transport. Cutting, crimping and loading of the terminals all take place on the same machine and the time-consuming storage of individual wires is eliminated. Stock levels of semi-finished products can also be reduced, resulting in faster responses to design changes and reducing the amount of material to be liquidated. Furthermore, it reduces the amount of work in progress.

Versatile seal insertion

The latest generation Komax S1441 seal module creates the ideal conditions for the efficient insertion of conventional seals and mini-seals.

Crimp modules capable of sequencing

The Omega machines feature several C1370 crimp modules with crimp force of up to 22 kN. Sequences and functions like the stroke and split cycle can be programmed easily for these modules. The integrated Crimp Force Analyzer (CFA+) guarantees the highest quality with minimal rejects.

Optical control of the strip and seal position

The Q1240 controls the stripping process during operation to ensure correct strip lengths and to check for pulled or splayed strands. The optional seal monitoring controls the positioning and can detect twisted and pierced seals.

Wire storage

The wire storage system is essential for the efficient production of complex double-sided wire harnesses. It enables the immediate post-production of defective wires and thereby ensures the full loading of complete wire harnesses and their easy removal from the machine.

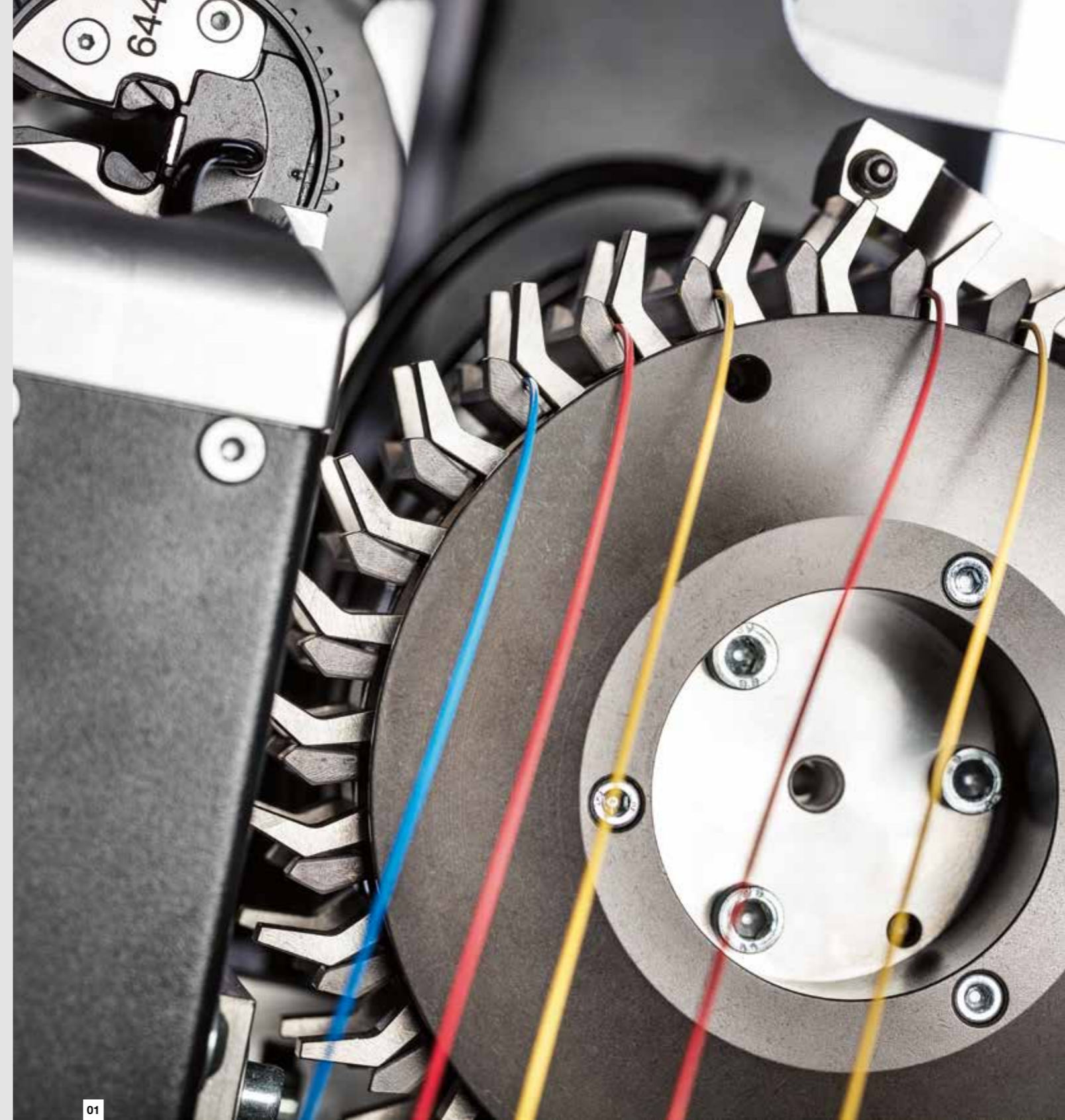

01



02

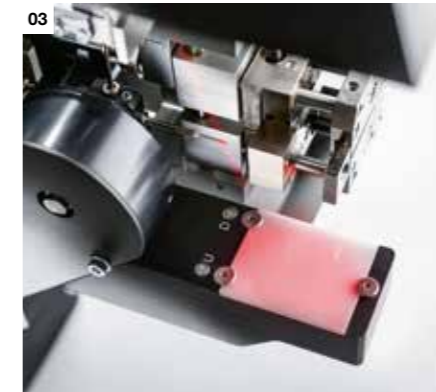

03

01
With the help of the wire storage system, double-sided wire harnesses with a high degree of complexity can easily be produced.
02
S1441 seal module for all conventional seals.
03
The integrated Q1240 strip and seal monitoring visually captures every individual wire end during production.

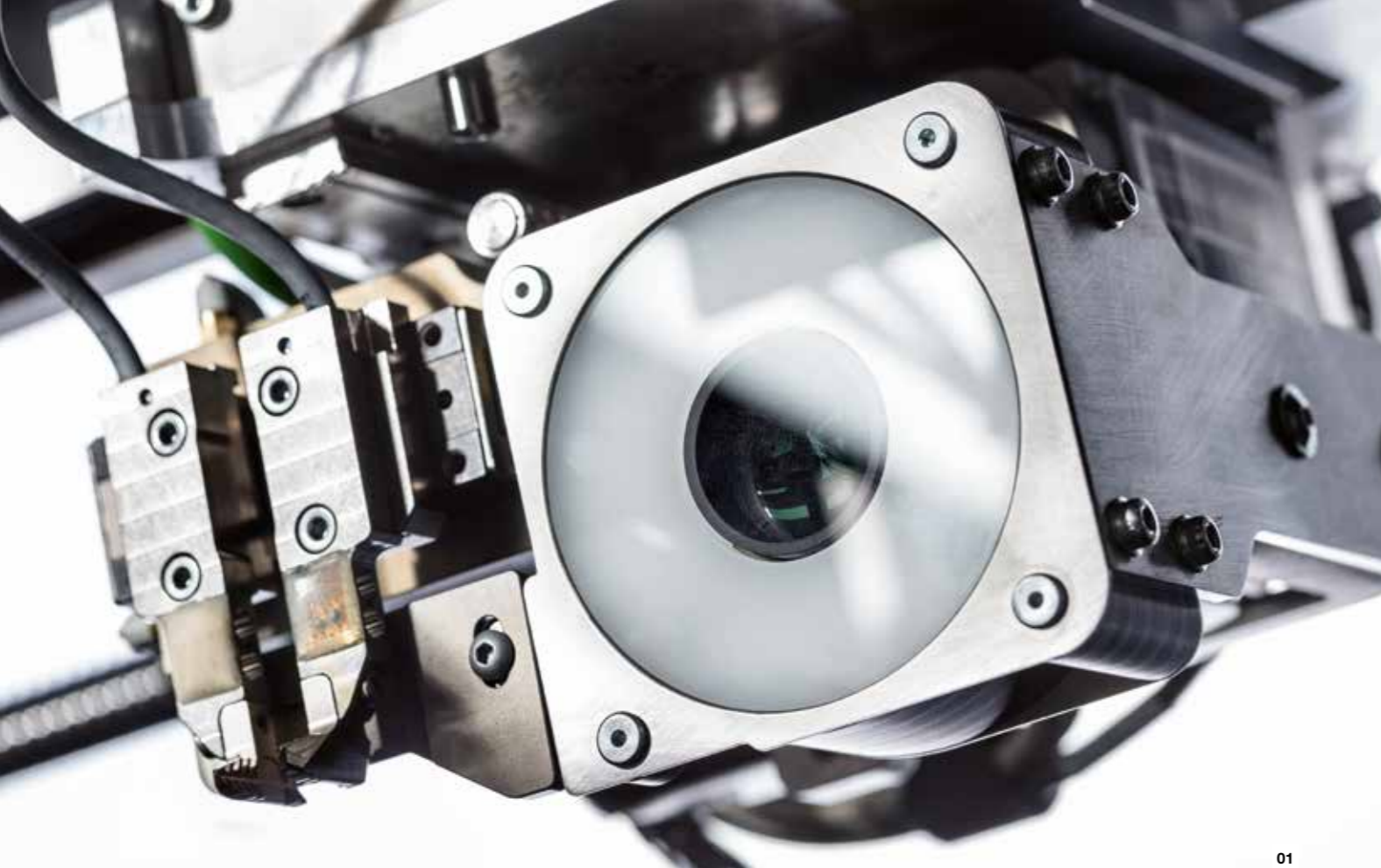

01
02

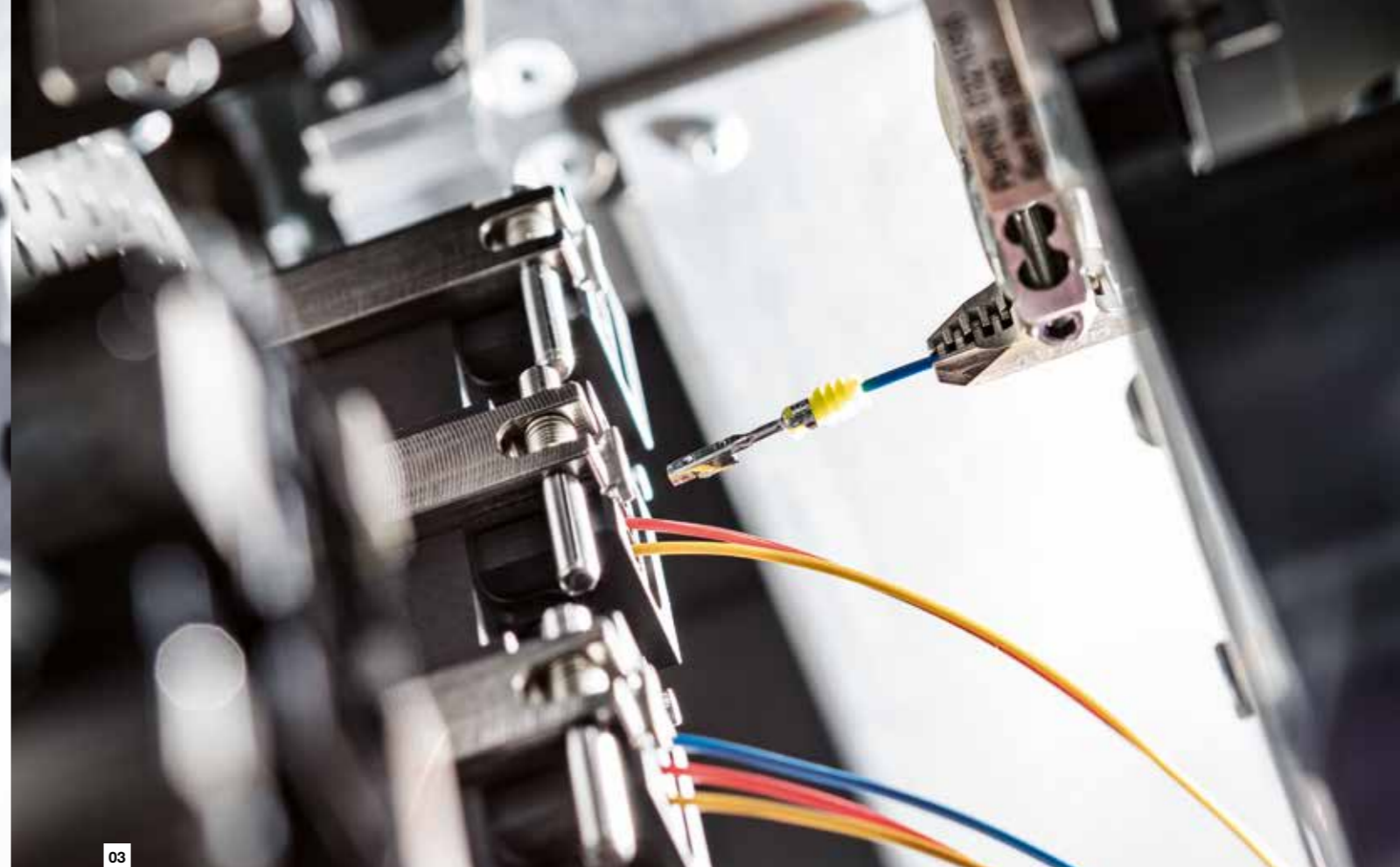
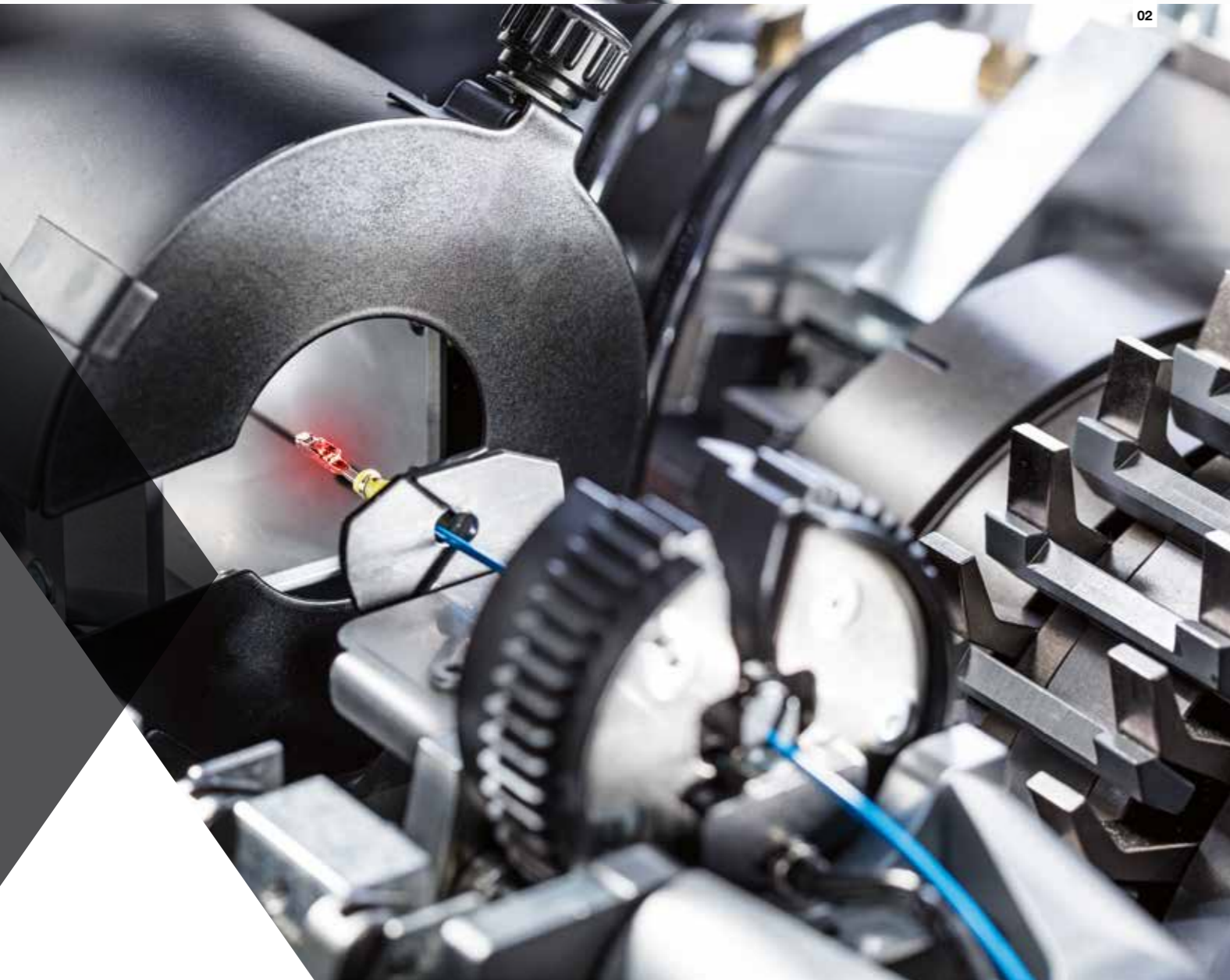

03

High flexibility and simple operation

The new fully automatic blockloaders with enlarged mounting pallets ensure even greater flexibility for specific manufacturing across a wide range of applications. They process wire harnesses in a single process step from A to Z and open up new possibilities for the required wire harnesses. Already created wire harnesses can be loaded again in seconds and re-produced. Thanks to individual configurations – the Omega 740 with five process modules and the Omega 750 with eight – changeovers and interruptions are reduced to a minimum.

New possibilities thanks to the optional OBMS block measuring

The visual measurement system measures the individual block cavities precisely using a camera system and enables the automatic loading of components that could only be processed manually until now.

Optical measurement system for terminals

To ensure the accurate placing of the terminals in the housing, the particular terminal must first be identified and measured. This

check is also carried out using an optical measurement system. This image enables the insertion head to be positioned precisely.

Pallet carousel for highly flexible block loading

The Omega 740/750 feature two large pallets to accommodate many different terminal housings. This makes it possible to load more types of housing on a single pallet and manufacture different wire harness configurations simultaneously, thus significantly increasing flexibility. The pallets are loaded and unloaded as the machine is running, while another wire harness is produced on the second pallet with the newly developed, rapid hybrid gripper.

Hybrid insertion gripper

The insertion gripper picks up the terminals and inserts them into the wire housing. The loading force is monitored throughout the entire process and checks made to ensure that the terminal locking is correct. A pull-off test checks that the terminal is correctly locked in place.

- 01 Individual block chambers can be measured precisely by the OBMS optical measuring system.
- 02 The optical terminal measurement system enables the loading of a wide range of terminals.
- 03 The insertion gripper monitors the loading force during the entire process and checks that the terminal locking is correct.
- 04 Large pallet with mounting fixtures for different connector housings

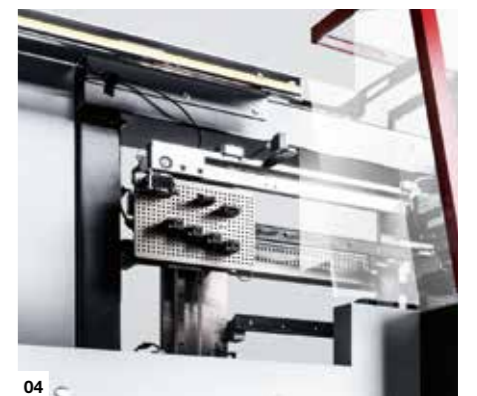

04

PLENTY OF SPACE

FOR 5 OR 8
PROCESS MODULES



X1582
TWISTING MODULE



X1585
FLUXING/TINNING
MODULE

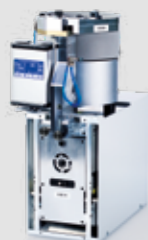

AEH-LS
FERRULE MODULE



CM 1/5 GS
FERRULE MODULE

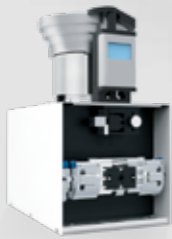

CM03
MIL CRIMP MODULE



C1370
CRIMP MODULE



S1441
SEAL MODULE



DC
DOUBLE GRIPPER MODULE



Q1240
OPTICAL
QUALITY MONITORING



OMEGA 745/755 APPLICATION MACHINE

The Omega application version has all the previously described benefits and properties of the Omega 740/750. What sets it apart is the automated solution developed specifically for the customer for the feeding and further processing of housings and the depositing of wire harnesses. The Omega 745/755 is not a ready-made product but a flexible basic machine with intelligent software, interchangeable process modules and customized application components to meet the special requirements and specific needs of our customers.

The customization aims to provide our customers with a decisive economic advantage. This is primarily achieved through rationalization and the associated savings in labor costs. Komax is the global market leader in the wire processing sector. Our applications allow our customers to benefit from the wealth of specialist knowledge and expertise of the Komax development team, enabling them to find a tailored solution that meets their every need.

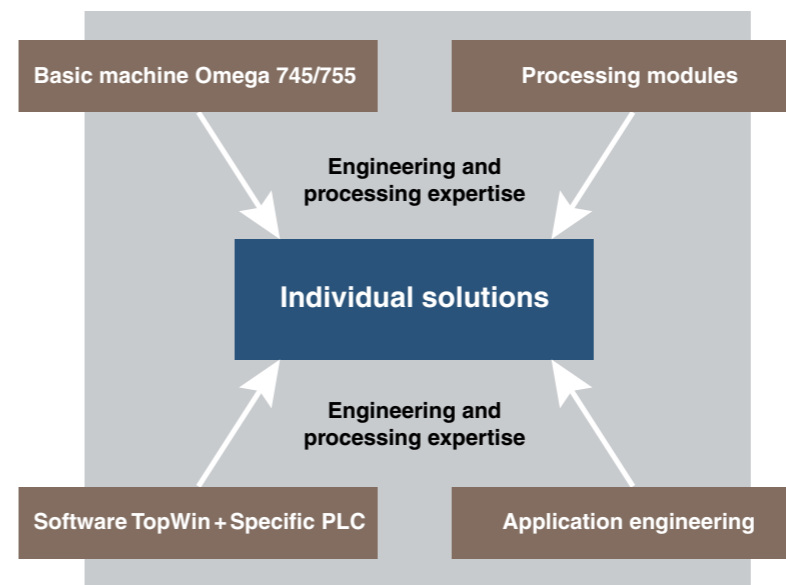

First-class engineering services – customized products

- The Omega 745/755 offers a customized block feed and deposit system for the wire harnesses.
- The fully automatic feeding system and processing of up to four different connector housings enables the production of wire harnesses with double-sided loading.
- The Omega 745/755 can be changed over to produce a different wire harness with minimal engineering effort. This flexibility means a high level of investment protection for our customers.

Integration of optional follow-on processes

- The base machine for the Omega 745/755 offers sufficient space for the integration of additional processes associated with loading, e.g.:
- Automatic closing of the secondary lock on the connector housings
- Optical process monitoring
- Reading of data matrix codes for product traceability
- and much more

Full automation for minimal labor requirement

- Specially customized solutions can result in even higher levels of automation and almost autonomous production.
- This rationalization means that one operator can operate and monitor several machines at once. Savings in labor costs can then be made.
- Full automation also minimizes operator influence on quality.



01



02



03



04

01
Flexible housing rail system: up to four different housing types can be supplied at the same time. Loading and unloading of the housing and the finished wire harnesses while the machine is running.

02
The terminal housing is supplied on a guide rail. The insertion gripper monitors the loading force during the entire process and checks that the terminal locking is correct.

03
Example of an additional function: a customized tool closes the secondary lock on the connector housing

04
Example of interim storage of finished product: the completed wire harnesses are collected on a customized rail of any length until they are unloaded by the operator.

Processing examples

Cutting		Wire draw-in	
Cutting pulled strands		Wire deposit system/spot taping	
Full stripping		Seal monitoring	
Half stripping		Crimp force monitoring	
Double insulation cable		Integrated crimp height measurement	
Crimping		Integrated pull-off force measurement	
Double crimping		Wire length correction	
Seal insertion		Splice detection	
Twisting/tinnying		Good/bad separation/ bad part cutting	
Sleeve insertion		Sequence processing	
Split cycle for closed terminals		Batch separation	
Ferrule crimping		Networking (MES, WPCS, MIKO)	
MIL crimping		Material change detection/ Material verification	
Solidifying, splicing and welding wire ends		Wire changer	
Inkjet printing		Programmable crimp height	
Block loading			

Options and accessories

Marking systems	Komax IMS inkjet marking system • Automatic inkjet print head changer
Wire draw-in	Expandable wire changer
Process modules	C1370 crimp module (with programmable crimp height) • S1441 seal module • MIL crimp • AEH ferrule module • Ultrasonic compaction
Quality assurance	Integrated crimp height measurement • Integrated pull-off force measurement • Crimp force monitoring CFA/CFA+ • Splice detection • Automatic conductor detector ACD • Material change detection • Material verification • Q1240 strip quality monitoring
Accessories	UPS • Warning lights
Software	WPCS networking interface • TopConvert data conversion • Komax MES

Technical data: Omega 740/750 and 745/755

	Omega 740/750	Omega 745/755
Piece output, single-sided and double-sided loading*	1.8 sec per insertion sequence	
Shortest wire length	For single-sided loading: 240 mm (9.45 in.) Double-sided jumper connections: 300 – 560 mm** (11.81 – 22.05 in.**) Complex loading: 300 – 780 mm** (11.81 – 30.71 in.**)	
Strip length	up to 25 mm (0.98 in.)	
Wire cross-sections***	0.13 – 2.5 mm ² (AWG 26 –14)	
Outer wire diameter	Max. 4 mm (0.16 in.)	
Usable transfer length Omega 74x	1880 mm (74 in.), up to five C1370 crimp modules	
Usable transfer length Omega 75x	2880 mm (113.4 in.), up to eight C1370 crimp modules	
Usable transfer length extension	1840 mm (72.4 in.) up to five additional C1370 crimp modules	
Wire changer	Max. 36 wires (in increments of six wires)	
Wire end storage	Rotary storage unit with a maximum of 30 storage spaces	
Process monitoring (integrated)	Collision monitoring (block chambers) Insertion force monitoring Terminal locking monitoring	
Block feed	Carousel with pallets	Fully automatic block feed by spiral or linear conveyor
Pallet system loading area (W×H)	280 × 200 mm (11.02 × 7.87 in.)	
Maximum width of connector housing	1st and 2nd housings: 100 mm (3.937 in.) 3rd and 4th housings: 60 mm (2.362 in.)	
Electrical connection	3 × 208 – 480 V, 50/60 Hz/10 VA	
Compressed air connection	6 bar (87 psi)	
Air usage	20 m ³ /h (707 ft ³ /h)	22 m ³ /h (777 ft ³ /h)

* Piece output is dependent on wire length and housing/terminal combinations.

** Dependent on wire harness structure.

*** Certain extremely hard, tough wires may not be able to be processed, even if they are within the indicated cross-sectional area. If in doubt, we are happy to provide you with samples of your wires.

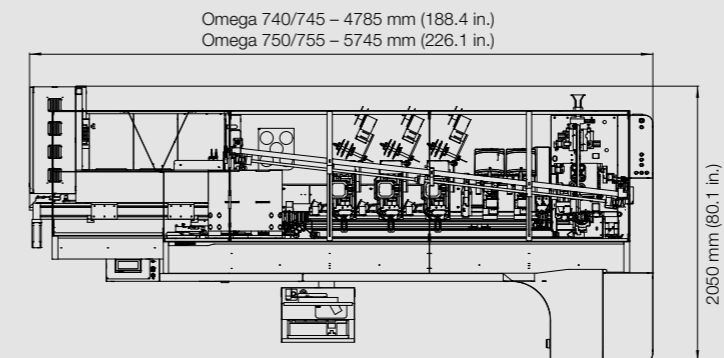

Machine height with closed protective hood 2060 mm (81.1 in.)
Machine height with open protective hood 2870 mm (113 in.)

Omega 745/755 – space required for customized feeding and deposit systems is not included.



Komax – leading the field now and in the future

As a pioneer and market leader in automated wire processing, Komax provides its customers with innovative solutions. Komax manufactures series and customer-specific machinery, catering to every degree of automation and customization. Its range of quality tools, test systems, and intelligent software and networking solutions complete the portfolio, and ensure safe, flexible, and efficient production.

Komax is a globally active Swiss company with highly qualified employees and development and production facilities on several continents. It provides local support to customers worldwide through its unique sales and service network and offers services that help them get the most out of their investments.

Komax AG
Industriestrasse 6
6036 Dierikon, Switzerland
Phone +41 41 455 04 55
sales.din@komaxgroup.com

komax
komaxgroup.com