



# KTR 5

Taping machine



## KTR 5

### **The entry level solution for long taping distances**

The KTR 5 is Komax's smallest product with an open winding head. The operator-controlled machine is ideal for taping wire harness lengths of 1.5 metres and over.

The open winding head ensures optimum handling, which is very important when taping long cables and branches. It allows very long wire harnesses to be placed in the machine from the side or from the front, which reduces the handling time.

As far as the length of the taping is concerned, there are no upper limits. Metre-long wires can be easily processed with the KTR 5.

### **New realms of productivity with the KTR 5**

The winding speed of the KTR 5 is twice as high as that of hand-guided devices. The machine also allows for material savings. Up to 25 percent less tape is required compared with manual taping.



A close-up photograph of a mechanical cutting device. The device features a large, curved metal housing with several screws. A red blade is visible, partially obscured by a black cable that is wrapped in a black braided sleeve. The cable is connected to a metal component with a multi-colored (red, yellow, blue) wire bundle. The background is a dark, solid color, and the overall image has a professional, industrial feel.

**INTEGRATED CUTTING  
DEVICE FOR OPTIMUM  
PRODUCTION TIME**

# MAXIMUM FLEXIBILITY IN PRODUCTION SETUP

THE KTR 5 CAN BE EASILY INTEGRATED  
INTO ANY PRODUCTION LINE AS A  
TABLETOP UNIT



### User safety at the highest level

- The KTR 5 meets the highest safety standards.
- The safety cover integrated into the winding head cover as standard ensures maximum operator safety during the taping process.

### The perfect introduction to taping with an open winding head

- Affordable solution for wire harness production with an open head.
- Low maintenance costs thanks to highest quality standards.
- Minimal training requirement due to foot pedal speed control.

### Maximum flexibility

- The KTR 5 impresses with maximum flexibility thanks to its compatibility with different tape materials and wire diameters.
- Its manually operated roller feed, in combination with the optional pulling tool, also ensures a high degree of flexibility in cable taping.
- Its limited space requirement and low weight also ensure a high degree of flexibility, as the machine can be easily integrated into any production process.



01

The manually operated roller feed ensures flexibility: The feed speed is easy to adjust using the lever.

02

Easy to use: The speed can be infinitely adjusted with the foot pedal.

03

Production at the highest level: the optional unwinding device prevents unwanted twisting and ensures the production of flexible cables.

04

Optional retrofitting pulling tool: The pulling tool ensures a uniform overlap from the first rotation and therefore minimises operator influence.

05

The safety cover integrated in the hood ensures maximum operator safety.



01



02

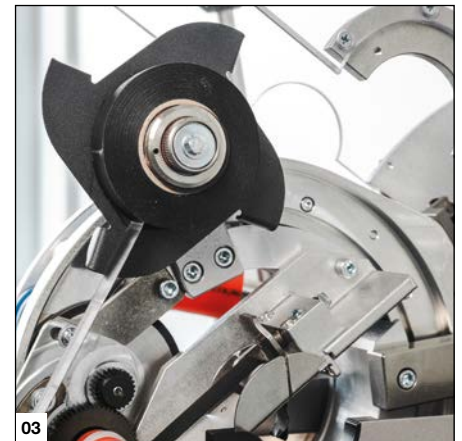

03

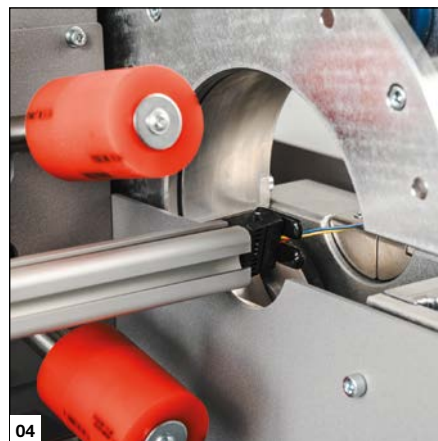

04

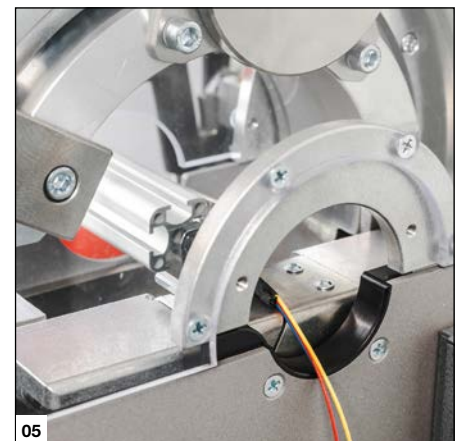

05



### **Wire harness processing without twisting**

Different adhesive tapes have different pull-off forces. Tapes with high pull-off forces often cause unwanted twisting during the taping process. The optional unwinding device helps to pull off the adhesive tape and prevents the cable from twisting. Depending on the type of adhesive tape, it can be individually adjusted or completely deactivated. Another advantage: the unwinding device results in flexible cables which can be fitted easily.

### **Komax fulfils customer requirements**

Depending on the specific customer requirements, Komax offers options for the KTR 5 that offer additional flexibility and higher quality with the production of wire harnesses.

### **Open winding head: long branches are easy as pie**

Taping long branches by hand is a very laborious task, and even with a machine, it can be difficult to feed the long branches through the winding head. The ergonomic cable feed when taping with an open winding head simplifies this process, however. An illustrative example is the taping of a motorcycle wiring harness. In this case, 1.5 metres are taped between two bundles with pre-taped branches. The pre-taped branches are simply placed through the open head and don't have to be threaded through a closed winding head.

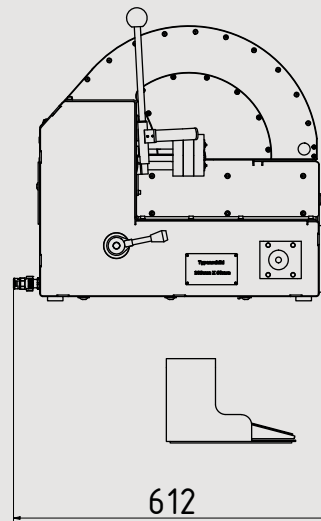
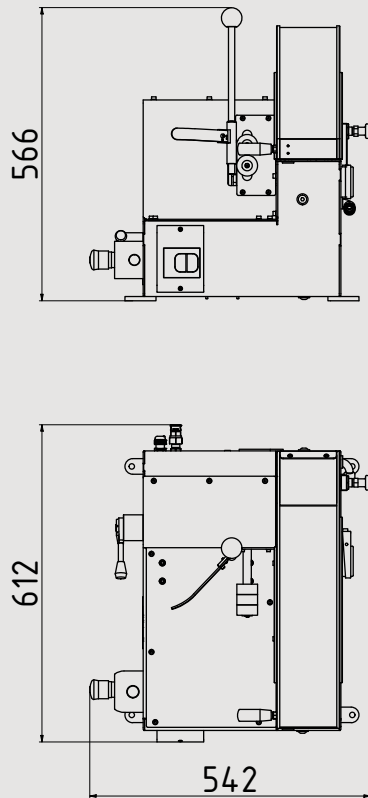

### Technical data – the KTR 5 at a glance

Application	taping of simple and long wire harnesses
<b>Adhesive tape and wire harness data</b>	
Wire harness diameter	max. 20 mm
Max. winding length	limited by tape length
Adhesive tape materials	a wide range of automotive and industrial adhesive tapes
Adhesive tape diameter	9–19 mm
Tape roller core diameter (standard)	1.5" and 3"
Maximum tape roller outer diameter	max. 180 mm
<b>Machine data</b>	
Winding head rotational speed	55–500 rpm, speed control continuously via foot pedal including winding head positioning
Feed type	roller feed
Feed rate	0–60 mm/turn, continuously adjustable
Electric connection	L/N/PE 200 – 240 V AC/50 Hz (optional: L1/L2/PE 110 V AC/50 – 60 Hz ±10%)
Pre-fuse	16 A
Connected load	550 W
Control voltage	24 V DC
Operating pressure	6 bar (0.6 Mpa / 87 pal)
Dimensions (H × W × D)	560 x 650 x 565 mm
Weight	approx. 85 kg

## Komax – leading the field now and in the future

As a pioneer and market leader in the field of automated wire processing, Komax provides its customers with innovative and sustainable solutions for any situation that calls for precise contact connections. Komax manufactures series and customer-specific machinery for various industries, catering to every degree of automation and customization. Its range of quality tools, test systems, and intelligent networking solutions complete the portfolio, and ensure safe and efficient production.

Komax is a globally active Swiss company with development and production facilities on several continents. Komax uses its extensive distribution and service network, which includes local companies and their employees, to support customers across the world on site, thus ensuring the availability and value of their investments after equipment commissioning through standardized service processes.

Komax Taping GmbH & Co. KG  
Am Grubener Weg 15  
D-36151 Burghaun  
Phone +49 6652 79362-0  
[sales.bgh@komaxgroup.com](mailto:sales.bgh@komaxgroup.com)